

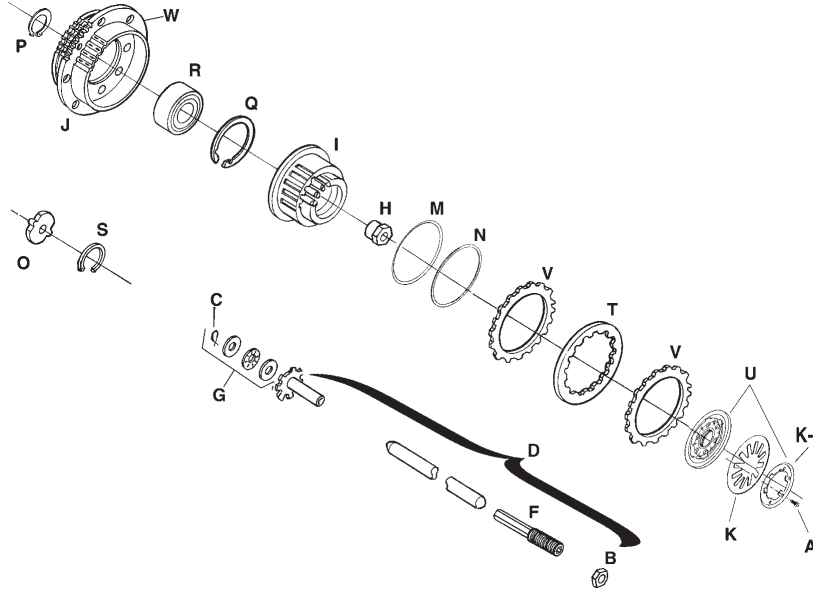

# 1998-up Clutch Pack Assembly



**1998-up Big Twin Clutch Parts.** Clutch Drum "J" has "W" Ring Gear installed.

| VT No.  | OEM       | #   | Item  |
|---------|-----------|-----|---|
| 12-0585 | 2980      | A   | Screw (6 used)                                      |
| 12-0563 | 7848W     | B   | Locknut   |
| 12-0923 | 11096     | C   | Retaining Ring                                      |
| 17-9252 | 37069-90  | D   | Pushrod Release Set                                 |
|         | 37088-90  |     |   |
|         | 37090-98  |     |   |
| 18-0169 | 37090-98  | F   | End, Rod, Left only                                 |
| 18-3623 | 37312-75  | G   | Bearing, Kit includes Thrust Washer (2)             |
|         | 37313-80  |     | Retaining Ring                                      |
|         | 11096     |     |   |
| 12-9914 | 37496-90  | H   | Mainshaft Nut                                       |
| 18-0160 | 37550-98  | I   | Clutch Hub (OE)                                     |
| 18-0171 | 37550-98  | I   | Clutch Hub (VT)                                     |
| 18-0588 | 31626-06  | I   | Clutch Hub (07-up)                                  |
| 18-0161 | 37707-98A | J   | Clutch Drum   |
|         |           |     | Includes Q and R                                    |
| 18-0589 | 37813-06  | J   | As Above 07-up                                      |
| 18-0180 | 37707-98A | J   | Clutch Drum Only                                    |
| 18-3126 | 37846-99A | J   | As Above Fits 1999-up FLT Fuel Injected Models Only |
| 18-3252 | 37871-98A | K   | Diaphragm Spring (BTE)                              |
| 18-8317 | 37871-98A | K   | Diaphragm Spring                                    |
| 18-3254 | 37951-98  | K   | As Above Screamin' Eagle Performance Spring         |
| 18-0163 | 37872-98  | K-1 | Spring Retainer                                     |
| 18-0164 | 37883-98  | M   | Damper Spring Seat                                  |
| 18-0165 | 37884-98  | N   | Damper Spring                                       |
| 18-8257 | 37903-90  | O   | Release Plate                                       |
| 18-8258 | 37904-90  | P   | Retaining Ring, External                            |
| 18-8259 | 37905-90  | Q   | Retaining Ring, Internal                            |
| 12-0160 | 37906-90  | R   | Bearing   |
| 18-8261 | 37909-90  | S   | Retaining Ring, Internal 1990-99                    |
| 18-8226 | 37909-00  | S   | Retaining Ring, Internal 2000-up                    |
| 18-3251 | 37913-98  | T   | Steel Plates (8)                                    |
| 18-0166 | 37912-98A | U   | Pressure Plate Kit                                  |
| 18-3250 | 37932-98  | V   | Plate Set (9)                                       |
| 18-8319 |           | W   | Starter Ring Gear                                   |



Order VT No. 18-0133 Complete Assembly 1998-06 5-Speed



**Clutch Hub.**

| VT No.  | Year    |
|---------|---------|
| 18-0171 | 1998-06 |
| 18-0588 | 2007-up |



12-0564



12-9914

**BT Clutch Hub Nuts** secure clutch hub to main shaft.

| VT No.  | OEM      | Fits    |
|---------|----------|---------|
| 12-0564 | 37496-84 | 1984-89 |
| 12-9914 | 37496-90 | 1990-up |

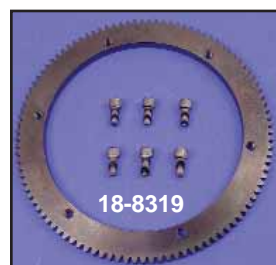

18-8319

**Big Twin Starter Ring Gears** for replacement on stock clutch drums only.

**Note:** Bolt on types include screws.

| VT No.  | Year    | Teeth      |
|---------|---------|------------|
| 18-8307 | 1991-93 | 66T        |
| 18-8308 | 1994-97 | 102T       |
| 18-8319 | 1998-up | 102T       |
| 37-0018 |         | Allen Bolt |



# Clutch Parts for 1991-97 BT

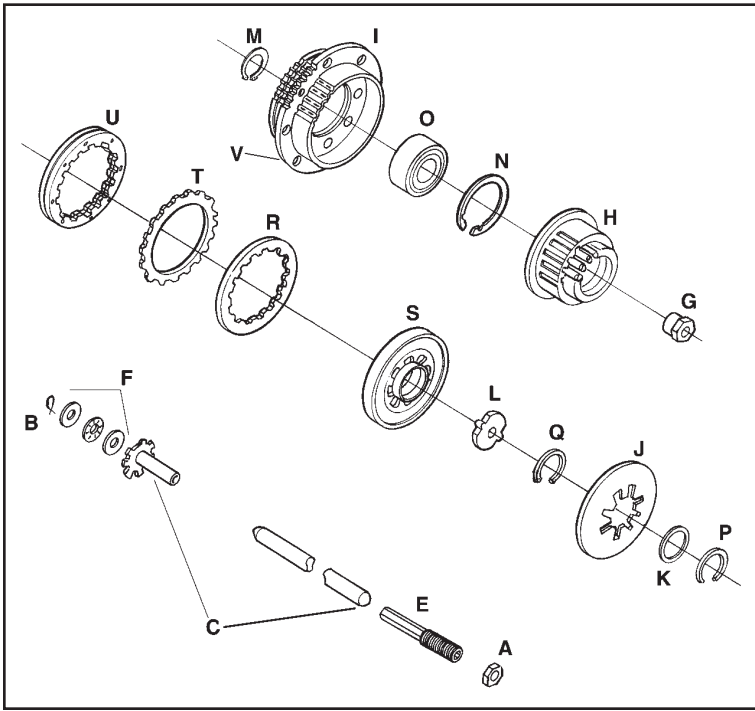

## 1991-97 Big Twin Clutch Parts.

| VT No.  | OEM       | # | Item                          |
|---------|-----------|---|-------------------------------|
| 12-0563 | 7848W     | A | Locknut                       |
| 12-0923 | 11096     | B | Retaining Ring                |
| 17-9250 | 37069-90  | C | Pushrod                       |
|         | 37088-90  |   | Release Set                   |
|         | 37090-84A |   |                               |
| 18-3253 | 37090-84A | E | End, Rod, Left only           |
| 18-3623 | Kit       | F | Bearing Kit                   |
|         | 37312-75  |   | Bearing                       |
|         | 37313-80  |   | Thrust Washer                 |
|         | 11096     |   | Retaining Ring                |
| 12-9914 | 37496-90  | G | Mainshaft Nut                 |
| 18-8254 | 37550-90A | H | Clutch Hub, OE                |
| 18-0159 | 37550-90A | H | As Above, V-Twin              |
| 18-8263 | 37707-90  | I | 91-93 Clutch Drum w/Gear, OE  |
| 18-8310 | 37707-90  | I | As Above, V-Twin              |
| 18-8223 | 37707-94  | I | 94-97, Clutch Drum w/Gear, OE |
| 18-8311 | 37707-94  | I | As Above, V-Twin              |
| 18-8308 | 102T      | I | Ring Gear Only                |
| 18-3234 | 37871-90  | J | Diaphragm Spring              |
| 18-8256 | 37872-90  | K | Spring Seat                   |
| 18-8257 | 37903-90  | L | Release Plate                 |
| 18-8258 | 37904-90  | M | Retaining Ring, External      |
| 18-8259 | 37905-90  | N | Retaining Ring, Internal      |
| 12-0160 | 37906-90  | O | Bearing                       |
| 18-8260 | 37908-90  | P | Retaining Ring, Internal      |
| 18-8261 | 37909-90  | Q | Retaining Ring, Internal      |
| 18-3231 | 37913-90  | R | Steel Plates (6), Barnett     |
| 18-8255 | 37912-91  | S | Pressure Plate                |
| 18-3230 | 37911-90  | T | Plate Set (8), Barnett        |
| 18-8262 | 37977-90  | U | Spring Plate, Smooth          |
| 18-8313 | 37977-90  | U | Spring Plate, Smooth          |
| 18-8307 | —         | V | Ring Gear 1990-92             |
| 18-8308 | —         | V | Ring Gear 1993-97             |



Complete Clutch Pack Assembly as shown.

| VT No.  | Years   |
|---------|---------|
| 18-0131 | 1991-93 |
| 18-0132 | 1994-97 |



**1991-97 Complete Clutch Hub** replaces stock units.  
**VT No. OEM Brand**  
**18-0159** 37550-90A V-Twin  
**18-8254** 37550-90A OE



# 1985-90 Big Twin Clutch Parts

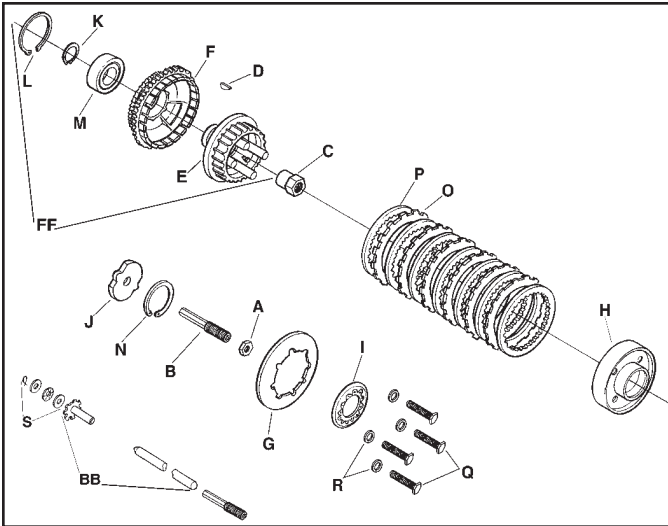

## 1985-90 1340 Big Twin Clutch Pack Hardware.

| VT No.  | #   | OEM       | Item                           |
|---------|-----|-----------|--------------------------------|
| 12-0563 | A   | 7848W     | Nut, 5 pack                    |
| 18-3259 | B   | 37357-84  | Adjusting Screw for Stock      |
| 18-3253 | B   | 37090-84A | Adjusting Screw for 18-3680    |
| 17-9246 | BB  | Kit       | Rod Set, 1985-86               |
| 17-9248 | BB  | Kit       | Rod Set, 1987-89               |
| 17-9249 | BB  | Kit       | Rod Set, 1990                  |
| 12-0564 | C   | 37496-84  | Nut, Mainshaft                 |
| 12-0212 | D   | 37523-85  | Key, 10 pack                   |
| 18-3679 | E   | 37550-84A | Clutch Hub                     |
| 18-8153 | E   | 37550-84A | Clutch Hub, V-Twin             |
| 18-3641 | F&M | 37702-84A | 84-E85 Clutch Drum w/Ring Gear |
| 18-8234 | F&M | 37707-84A | L85-90 Clutch Drum w/Ring Gear |
| 18-8290 | G   | 37875-86A | Diaphragm Spring               |
| 18-0186 | FF  | Kit       | 1984-E85 Drum/Hub Assembly     |
| 18-0187 | FF  | Kit       | E1985-90 Drum/Hub Assembly     |
| 18-3680 | H   | 37901-84A | Pressure Plate                 |
| 18-3214 | I   | 37902-86B | Barnett Adjuster Plate         |
| 18-3255 | I   | As Above  | V-Twin                         |
| 18-3215 | J   | 37903-84  | Release Plate                  |
| 12-0953 | K   | 37904-84  | Ret Ring External, 10 pack     |
| 12-0954 | L   | 37905-84  | Ret Ring Internal, 10 pack     |
| 12-0308 | M   | 37906-84  | Bearing                        |
| 12-0955 | N   | 37907-84  | Retaining Ring, 10 pack        |
| 18-1147 | O   | 37931-84  | Friction Disc, 6 pack          |
| 18-1148 | P   | 37975-84  | Drive Disc, 7 pack             |
| 37-8944 | Q   | 2881W     | Bolt and Washer                |
| 37-9272 | R   | 6242W     | Washer                         |
| 18-3623 | S   | Kit       | Bearing Kit                    |
| 12-0923 | T   | 11096     | Retaining Ring                 |

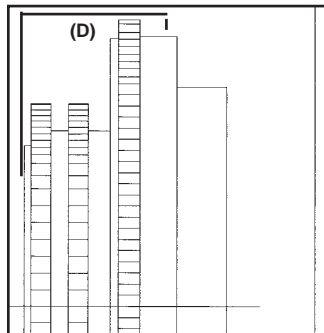

Complete Assembly 1985-90. VT No. 18-0130



1984-90 Big Twin Clutch Hubs feature the updated factory construction which has a machined steel center with aluminum outer

splined ring, secured by allen screws, with steel studs welded in place. Order related hardware separately.

| VT No.   | OEM       | Year    | Type   |
|----------|-----------|---------|--------|
| 18-3679  | 37550-84A | 1984-90 | OE     |
| 18-8153  | As Above  | 1984-90 | V-Twin |
| 18-8170* | 37550-84  | 1984-90 | V-Twin |



\*Note: Early style hub with aluminum studs

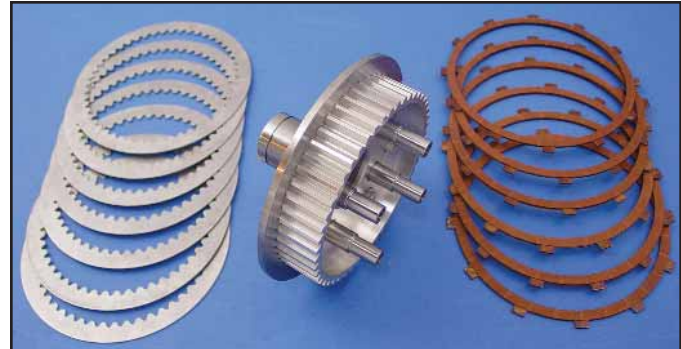

1984-89 BT Clutch Hub Kit includes updated reinforced steel center clutch hub, steel drive plate set & friction plate set.

VT No. 18-0541



1985-90 Clutch Hub Sleeve is a reinforcement ring for hubs at the tapered end. Sleeve is pressed on with beveled side out toward inner primary, after clutch drum with bearing is set over hub, so that clutch drum and hub will be installed as one unit.

| VT No.  | Type                     |
|---------|--------------------------|
| 18-8240 | Alum. 1-piece type hub   |
| 18-8241 | Steel two-piece type hub |

## Clutch Drum and Hub Assembly.

Bearing and snap ring are installed in drum. Starter ring gear offset dimension shown.

| VT No.  | Year     | Size (D) |
|---------|----------|----------|
| 18-0186 | 1984-E85 | 1.670    |
| 18-0187 | E1985-90 | 2.087    |



**Barnett Scorpion Clutch Kit** features over twice as much friction surface area compared to stock clutch. All Scorpion Clutches provide a positive engagement and release. Scorpion clutches incorporate 6 heavy duty coil springs. In addition,

an extra spring set with a different spring rate is included which allows the clutch to be tuned for street or race application depending on usage. Tunability is easy without removal of the primary cover. Barnett Friction Plates are compatible with any primary oil. Each kit is designed to be used with stock type clutch basket.

- VT No. Fits**  
**18-3833** 1986-89  
**18-3842** 1990-97  
**18-3852** 1998-up



**BDL Competitor Clutch Kit** features 9 springs and shoulder bolts for simple adjustment, large 40mm double row hub bearing, polished pressure plate and Kevlar clutch.

- VT No. Fits**  
**20-0628** 1990-97 Evo Big Twin w/Chain Primary Drive  
**Replacement Friction/Steel Sets for Above**  
**VT No. Fits**  
**18-0548** 20-0628



**18-3697**

**Clutch Spring Conversion** by Barnett. Machined pressure plate that will eliminate stock type diaphragm spring and allow the use of coiled spring for more tunability and more positive linear clutch action.

- VT No. Fits**  
**18-3697** 1984-89 Big Twins  
**18-3698** 1998-up Big Twins



**18-3698**



## Pro-Clutch by Rivera Engineering



**Pro-Clutch by Rivera Engineering** converts old style clutch packs to smooth modern diaphragm spring function. Available for early chain or belt drive with wet or dry clutch. Kit includes clutch hub with bearing, clutch discs (friction and steel), diaphragm spring, spring retainer, pressure plate & 4 shoulder bolts. 84-up kits utilize existing clutch basket, supplies a clutch hub to allow use of clutch plates that increase surface area by 100% to reduce slipping.

- VT No. Clutch Basket Type**  
**20-0549** 1984-89 Chain  
**20-0550** 1990-97 Chain  
**20-0580** 1998-06 Chain  
**20-0732** 2006-up Dyna & 2007-up Big Twins  
**16-0310** Puller Tool

- Replacement Friction/Steel Sets for Above**  
**VT No. Fits**  
**18-0544** 20-0549, 1984-89 Chain  
**18-0545** 20-0550, 1990-97 Chain  
**18-0546** 20-0580, 1998-up Chain



## Clutch Paks

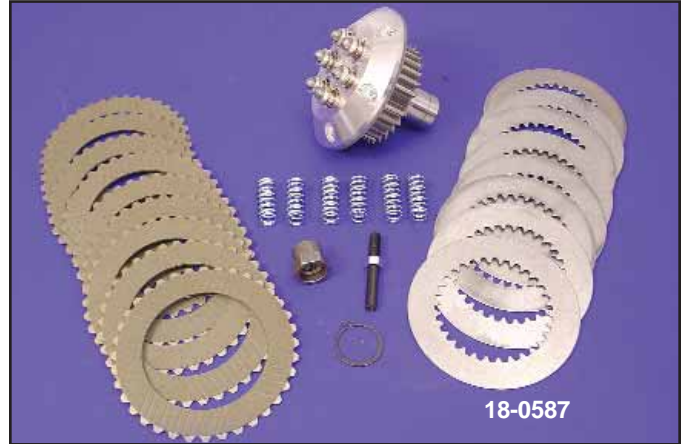

**18-0587**



**18-0586**

**York Hi Performance Clutch Kits** have been especially designed for better clutch operation and to deliver more torque & horsepower capacity, all parts are made from the highest quality materials to ensure a trouble free operation. The Kevlar clutch plates are made for heavy duty operation and deliver a smooth power transfer to the rear wheel. The adjustable coil springs allow you to tailor your clutch lever pressure & clutch operation as needed. These kits also boast very low maintenance, "Set it & Forget it." They are great upgrade kits.

- VT No. Year**  
**18-0587** 1990-97  
**18-0586** 1998-06



# Big Twin Clutch Packs

**Big Twin Clutch Packs** feature stock style components for a complete clutch installation.

| VT No.  | Year     |
|---------|----------|
| 18-0134 | 1984-E85 |
| 18-0130 | 1985-90  |
| 18-0131 | 1991-93  |
| 18-0132 | 1994-97  |
| 18-0133 | 1998-06  |



## Primary Drive Assembly

**Primary Drive Assembly Kit** includes clutch pack assembly, chain, chrome inner and outer primary covers with all bushings, seals, spacers, gaskets and mount screws including the starter jack shaft assembly.

| VT No.  | Years   | Model |
|---------|---------|-------|
| 43-1001 | 1991-93 | ST    |
| 43-1002 | 1994-97 | ST    |
| 43-1000 | 1998-06 | ST    |
| 43-1003 | 1994-05 | FXDWG |

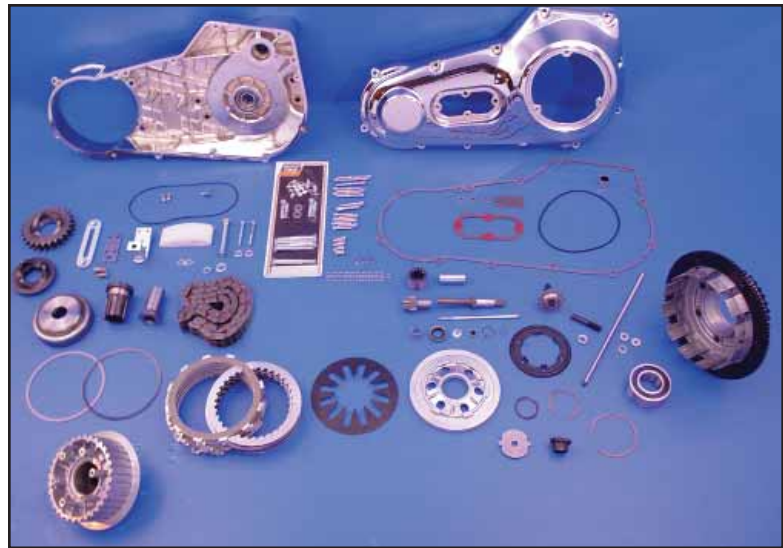

**Primary Chain Drive Systems** for Big Twins include 76 or 82 link Diamond Primary Chain, chain shoe adjuster assembly, clutch drum basket with starter ring gear and steel & fiber clutch plates with pressure plate assembly. Correct front compensator sprocket assembly includes all parts necessary for installation. Including sprocket nut. 5 Speed Big Twin Softail models and all pre1985 FLH-FX 4-Speeds require 82 link primary chains, 1980-up FLT-FXR 5-Speeds require 76 link primary chains.

| 82 Links | 76 Links | Year    |
|----------|----------|---------|
| 18-0102* | 18-0114* | 1998-06 |
| 18-0103* | 18-0113* | 1994-97 |
| 18-0104* | 18-0112* | 1991-93 |
| 18-0105* | 18-0111* | 1985-90 |

\*Note: Units include compensator front sprocket assembly.



- Series K™ clutches perform flawlessly under extreme heat conditions
- Smooth precise shifting
- Steel backing plates for maximum strength
- Kevlar is the most durable friction material made.
- 100% asbestos free

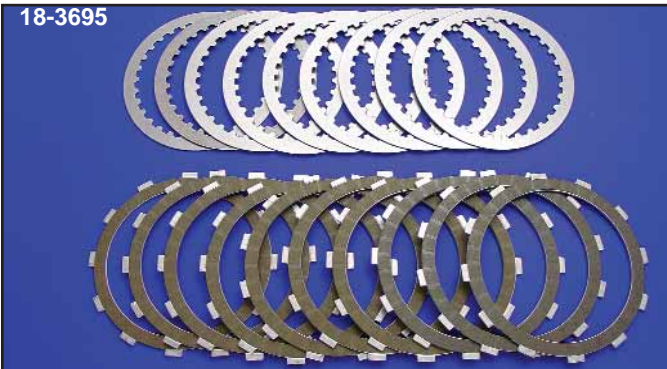
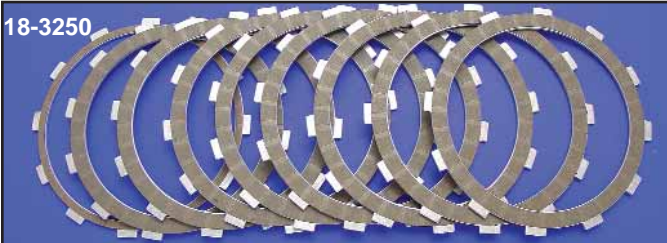
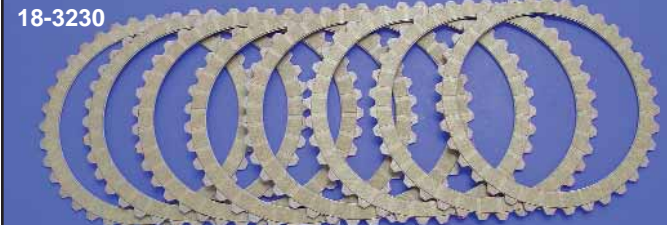

| VT No.              | Note | OEM         | MFG#      | Item                        |
|---------------------|------|-------------|-----------|-----------------------------|
| <b>Fits 1984-89</b> |      |             |           |                             |
| 18-1147             | A    | 37930-84    | HDP-9K    | Friction Plate (6)          |
| 18-1148             |      | 37975-84    | HDP-10    | Steel Set (7)               |
| <b>Fits 1990-97</b> |      |             |           |                             |
| 18-3230             |      | 37911-90    | HDP-11K   | Friction Plate (8)          |
| 18-3245             | E    |             | HDP-11RM  | Friction Plate (8)          |
| 18-3231             | C    | 37975-90    | HDP-12    | Steel Set (6)               |
| 18-3233             | F    | Extra Plate | HDP-11EPK | Extra Plate<br>Friction Set |
| <b>Fits 1998-up</b> |      |             |           |                             |
| 18-3250             |      | 37932-98    |           | Friction Plate (9)          |
| 18-3251             |      | 37913-98    |           | Steel Set (8)               |
| 18-3695             | H    | Extra Plate | HDP-13EPK | Extra Plate                 |

**Notes**

- A. Plates are 25% wider than stock for a greater surface area contact.
- C. Stock double riveted Drive Plate must be re-used.
- D. OEM replacement type, Not Genuine Barnett
- E. Bonded with carbon graphite compound by Raybestos.
- Dry flex clutch. Includes steel plates. For dry clutch conversion only. 1990-up models will not reuse spring plate.
- F. Consist of 9 Friction Plates and 8 Steel Plates. Add 12% more surface area to clutch double steel Drive Plate not used with kit.
- G. 1967 & older models, 1 extra steel plate is required.
- H. Consists of 10 friction plates and nine steel plates. Adds 11% more surface area.



**BT Clutch Adjusting Screws** sold each.

| VT No.  | OEM       | Years   |
|---------|-----------|---------|
| 18-3259 | 37357-84  | 1985-90 |
| 18-3253 | 37090-84A | 1991-up |



# Big Twin Clutch Kits



**Dry Flex Clutch Sets** by Barnett, feature friction material of Carbon Graphite by Raybestos. For use as a dry clutch

on Big Twin models. HDP11RM. Fits 1990-97. \*Note: Includes steel plates. The 1990-up will not reuse spring plate.

VT No. 18-3245\*

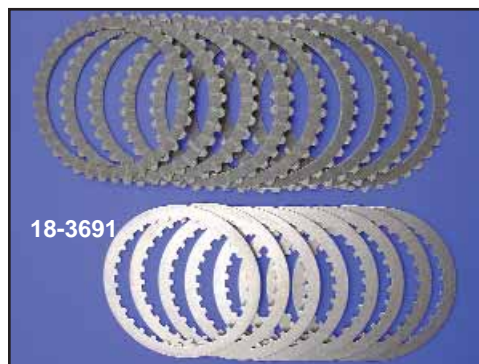

**Carbon Fiber Clutch Sets** by Barnett. Carbon fiber clutches feature excellent lubricity and very good energy absorption.

| VT No.  | Mfg#       | Year    | Clutch Type | Note |
|---------|------------|---------|-------------|------|
| 18-3693 | HDP-9CF    | 1984-89 | Wet         | 1    |
| 18-3690 | HDP-11CF   | 1990-97 | Wet         |      |
| 18-3691 | HDP-11EPCF | 1990-97 | Wet         | 2    |
| 18-3694 | HDP-13CF   | 1998-up | Wet         |      |

**Note 1:** Plates are wider than stock. Adds 25% more surface area.

**Note 2:** Consists of nine friction plates and eight steel plates. Adds 12% more surface area double steel drive plate is not used.



**Barnett Diaphragm Clutch Spring.**

| VT No.  | OEM       | Model                  | Item   |
|---------|-----------|------------------------|--------|
| 18-3213 | 37871-84  | 1984-89 BT             | Spring |
| 18-8291 | 37871-90  | 1990-97 BT Std.        | Spring |
| 18-8306 | —         | As Above, 25% stronger | Spring |
| 18-3252 | 37871-98  | 1998-up BT             | Spring |
| 18-0166 | 37912-98  | 1998-up BT             | Kit    |
| 18-3255 | 37902-86B | 1984-89 Adjuster       | Plate  |



# Police Clutch Kit

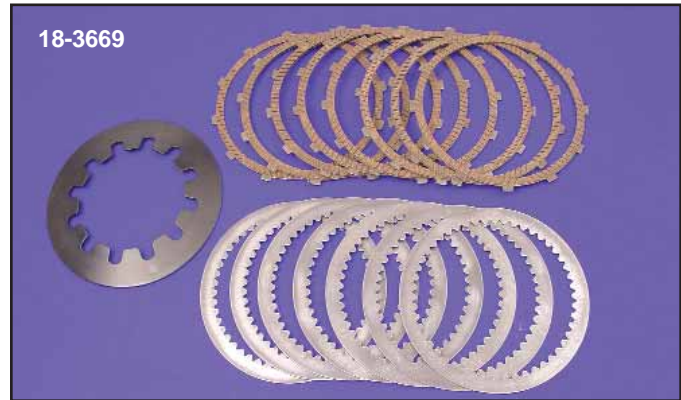
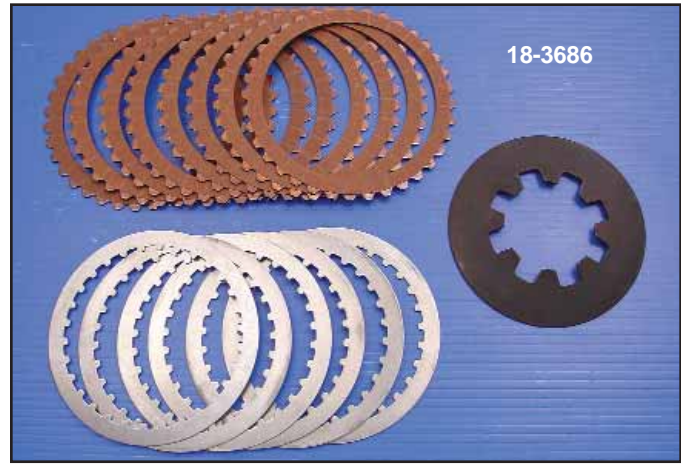
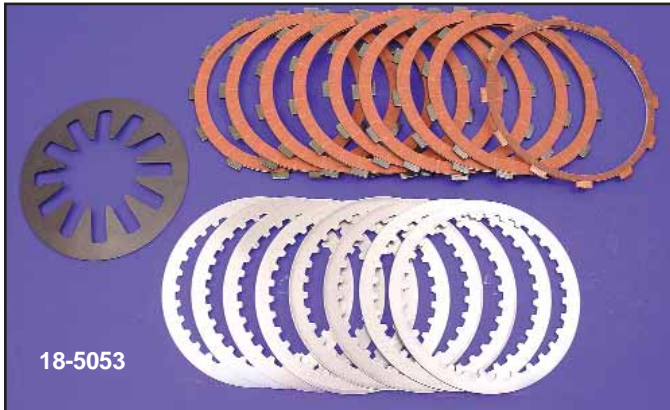

**Clutch Pak-Kit.** Heavy duty factory "wet" type for Big Twins, complete kit includes our original bonded police Kevlar clutch steel plates with diaphragm spring.

| VT No.  | Year    |
|---------|---------|
| 18-3669 | 1985-89 |
| 18-3686 | 1990-97 |
| 18-5053 | 1998-up |

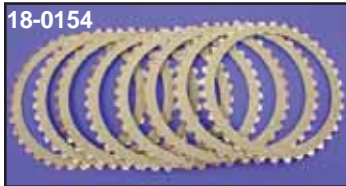

**Kevlar Clutch Sets Only,**  
order steels separately.

| VT No.  | Year    |
|---------|---------|
| 18-3676 | 1985-89 |
| 18-0154 | 1990-97 |

## ALTO Clutch Sets

KEVLAR CLUTCH SET

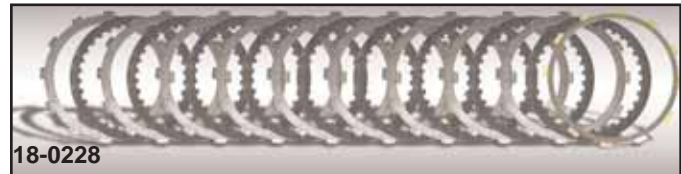

**Alto Clutch Sets.** Available in fibers & steel. Sold Kevlar or Red Eagle type. Both are bonded to steel.

### Alto Clutch Sets For Big Twin Models

|         |         |                         |
|---------|---------|-------------------------|
| 18-8281 | 1984-89 | Red Eagle               |
| 18-8292 | 1984-89 | Kevlar                  |
| 18-8290 | 1984-89 | Diaphragm Clutch Spring |
| 18-8276 | 1990-97 | Red Eagle               |
| 18-8299 | 1991-97 | Kevlar                  |
| 18-8315 | 1998-up | Red Eagle               |
| 18-8316 | 1998-up | Kevlar                  |
| 18-8317 | 1998-up | Diaphragm Spring        |

### Steel Plates For Big Twin Models

|         |         |     |
|---------|---------|-----|
| 18-8289 | 1984-90 | Set |
| 18-8286 | 1990-97 | Set |
| 18-8318 | 1998-up | Set |

**Alto Carbonite Power Pack Clutch Kits** for Big Twin include friction and steel plates. Friction plates feature 3M carbon based friction material to withstand high friction and heat temperatures. Steel plates are melonite treated for better engagement and cooler running. Order spring plate separately.

| VT No.  | Year    |
|---------|---------|
| 18-0226 | 1984-89 |
| 18-0227 | 1990-97 |
| 18-0228 | 1998-up |